

Installation Guide

for Andersen® 1-1/2" Self Storing Storm Doors



Please Do Not Return Product to Store!

PLEASE call the storm door Solution Center at 1-800-933-3626

with any questions regarding installation, mis-cut part replacement, lost part replacement, or anything else related to your storm door purchase.

- If your abilities do not match the requirements of this installation, contact an experienced contractor.
- Andersen has no responsibility in regard to the post-manufactured assembly and installation of Andersen products.



PARTS OVERVIEW

Your storm door should contain the following parts:

- 1 Door Frame Assembly
- 2 - Rain Cap
- 3 - Latch Rail
- 4 - Sweep
- 5 - Handle Clip
- 6 - Spacer Clips (2)
- 7 - Bottom spacer
- 8 Short Mounting Flange
- 9 Tall Mounting Flange
- 10 Ventilating Window
- 11 Retractable Screen
- 12 Decorative Trim Plate (1 or 3)
- 13 Screw Covers (3)

Not Shown

- 14 Hinge Rail
- 15 Handle Set Kit
- 16 Closer Kit
- 17 Window Handle Kit

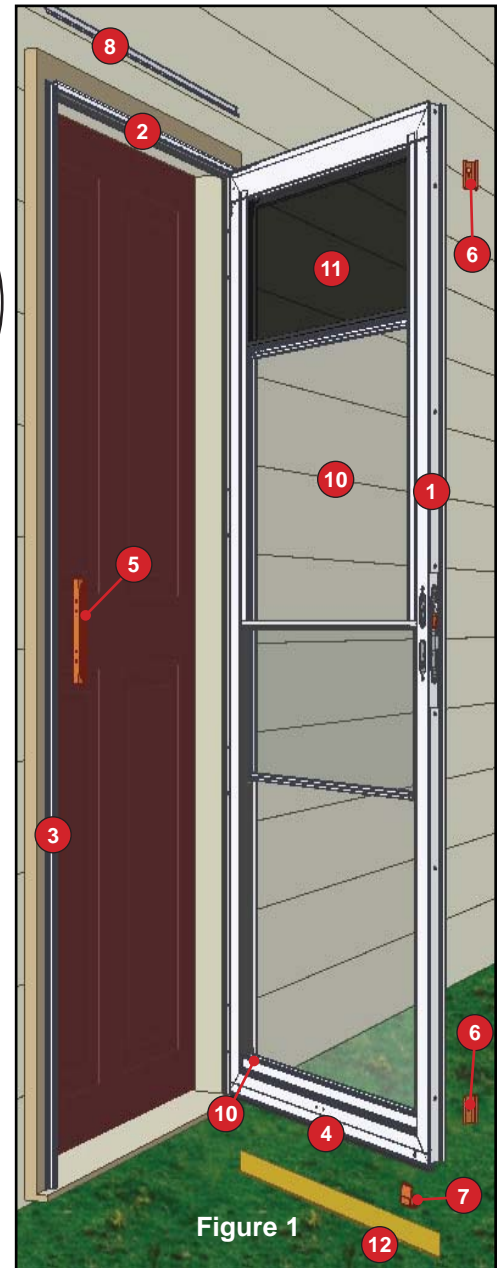
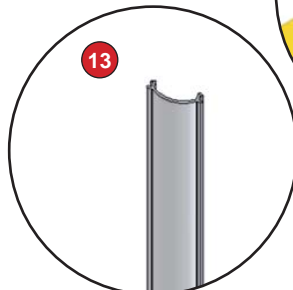
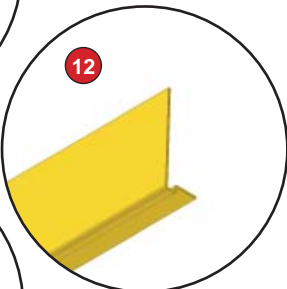
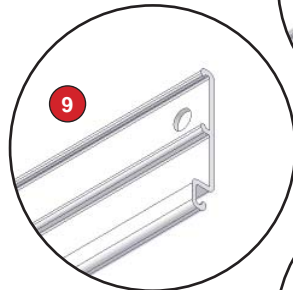
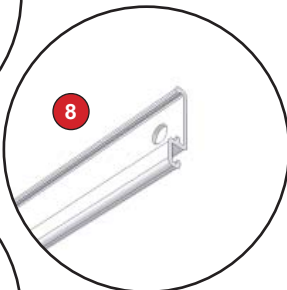
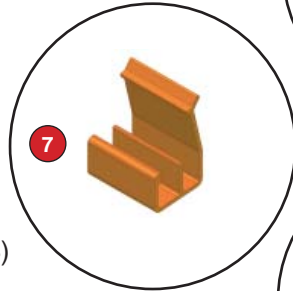
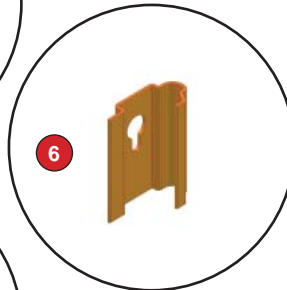





Come home to Andersen.

EMCO Enterprises, Inc., is a wholly owned subsidiary of Andersen Corporation. EMCO manufactures and supports the limited warranties for Andersen® and EMCO® doors. "Andersen", "EMCO" and all other marks where denoted are trademarks of Andersen Corporation. ©2011 Andersen Corporation. All rights reserved.

EMCO Enterprises, Inc.
PO Box 853
Des Moines, IA 50306-0853
Rev 9-2011 10043
P/N 618832



SAFETY FIRST - PLEASE READ AND FOLLOW ALL WARNINGS AND CAUTIONS IN THIS GUIDE.

| | | | | |
|---|--|---|---|---|
|  WARNING |  WARNING |  WARNING |  WARNING |  WARNING |
| Entry door hardware and handle may become hot when exposed to sunlight. | Improper use of hand or power tools could result in injury and/or product damage. Follow equipment manufacturer's instructions for safe operation. Always wear safety glasses. | Windows and doors can be heavy. Use safe lifting techniques and a reasonable number of people with enough strength to lift, carry, and install window and door products to avoid injury and/or property damage. | The insect screen is intended for reasonable insect control and not the retention of objects or persons within the interior. The insect screen material will not stop a person from falling through the door. | Metal fasteners and other hardware components may corrode when exposed to preservative treated and fire-retardant treated lumber. Obtain and use the appropriate size stainless steel fasteners and hardware as called out by the installation guide to fasten unit to any rough opening made from pressure treated and fire-retardant treated lumber. Failure to use the appropriate materials for the installation may cause a failure resulting in injury, property or product damage. |

RECOMMENDED TOOLS

• Safety Glasses



• Drill



• Screwdrivers



• Tape Measure

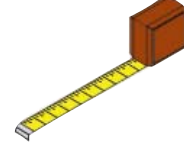

1. VERIFY MOUNTING REQUIREMENTS

To install the storm door, you must verify that there is the necessary opening width and height and a sufficient mounting surface.

1. Measure the width at the top, middle, and bottom of the opening (Figure 2). Measure from the inside of the brick mold or exterior trim.
2. Measure the height at the center of the opening. Measure from the inside of the brick mold or exterior trim, down to the top of the bottom sill.

Use the this table to determine if your storm door will fit into the opening:

| Nominal Storm Door Sizes | Opening Sizes | |
|--------------------------|--------------------|----------------|
| | W 1 - 3 (width) | H (height) |
| 36" x 80" | 35 7/8" TO 36 3/8" | 80" TO 80 7/8" |
| 34" x 80" | 33 7/8" TO 34 3/8" | |
| 32" x 80" | 31 7/8" TO 32 3/8" | |

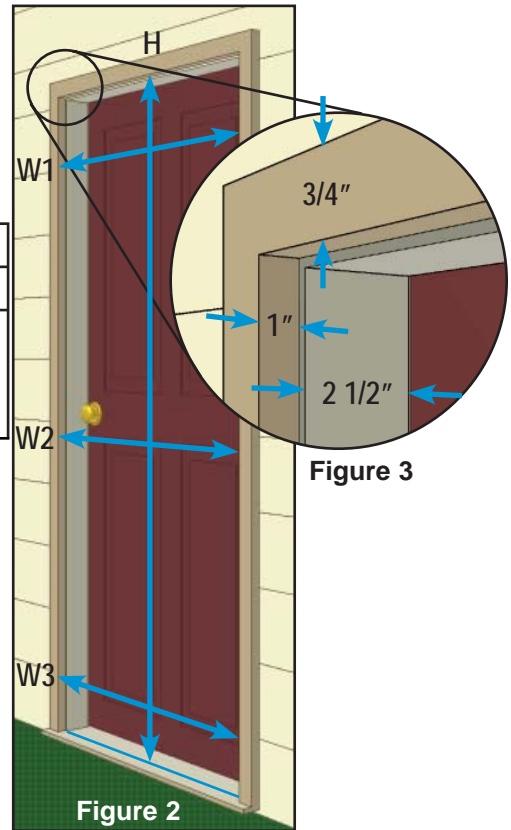

3. Make sure that the brick mold or exterior trim meets the mounting surface requirements to install the rain cap, hinge rail and latch rail (Figure 3). You must have a minimum of:
 - 1" mounting surface depth. *
 - 3/4" mounting surface front.
 - 2 1/2" space between the existing door and the mounting surface for the handle set installation.
4. If your opening does not meet the 1" mounting surface depth (ie: flat casing or 1x4 trim), you will need to attach shims to the face of your trim to create the required 1" depth. A recommended solution is to purchase insect screen molding and attach to your trim with 3/4" brad nails.
5. If entry door sill is bent or damaged, product may not install correctly. Replace bent or damaged entry door sill prior to storm door installation
6. Most homeowners prefer to have the storm door handle on the same side as the entry door handle. In shallow door openings, this can cause the two handles to interfere. Check for potential interference using the rough measurements (Figure 4). If you anticipate that there will be interference, purchase a storm door that is hinged on the opposite side of you entry door.

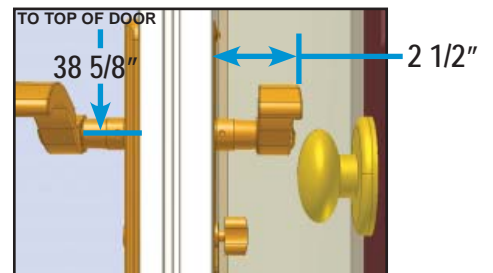

* For opening widths up to 1" wider or for mounting surface depth between 5/8" - 3/4", please call our Solution Center at 1-800-933-3626 to purchase a special kit to accommodate your situation.

2. INSTALLATION PREPARATION:

Tools needed:



3 - #8x1/2"

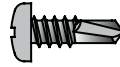

In this step, you will confirm your storm door hinges on the correct side.

1. Confirm your storm door hinges correctly by using your measurements from step 1 and comparing your door to figures 5 and 6.

In this step, you will attach the decorative trim plate to your door.

IMPORTANT: Steps 2 - 5 must be completed before the door is placed in opening because screws must be installed in the bottom of the door.

NOTE: Your door may contain several decorative trim plates with various finishes. Select the finish that matches your handle and install as instructed, or skip this step if a decorative trim plate is not desired.

2. Position the door on a protected surface so the exterior side of the door is facing up.

TIP: Lay on door carton

3. Starting at the mitered corners, remove clear protective tape from bottom of door, and the bottom 3" of the door sides.
4. Place decorative trim plate onto the door and align edge of trim plate with latch side edge of door frame. (Figure 7)
5. Fasten sweep trim plate to door frame using three #8 x 1/2" self drilling screws. (included in closer kit)

In this step, you will ensure all clips are properly attached to the door and mounting components

6. Remove door from carton, grasping the door as shown

NOTE: when lifting the door, support the weight of the door by the door frame, not the hinge and latch rails.

7. With door standing, ensure latch rail is properly seated in the orange spacer clips (Figure 8B), and ensure bottom spacer is attached to the bottom of the door and is slid to the handle side. (Figure 8A)

NOTE: See troubleshooting section at the end of the install guide if bottom spacer becomes detached from the door frame.



Figure 5



Figure 6

EXTERIOR
VIEWS

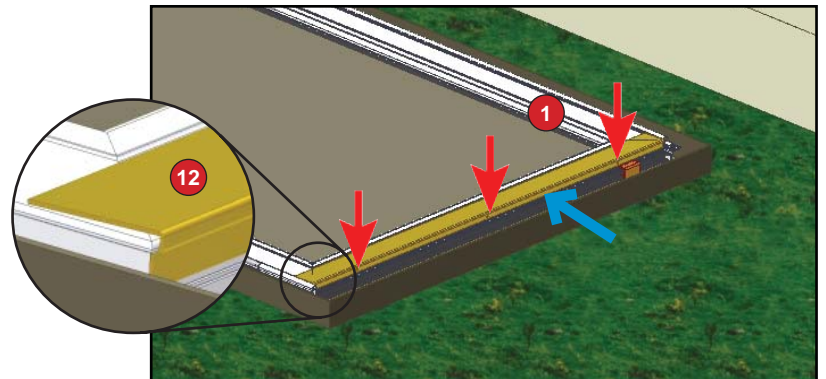

Figure 7

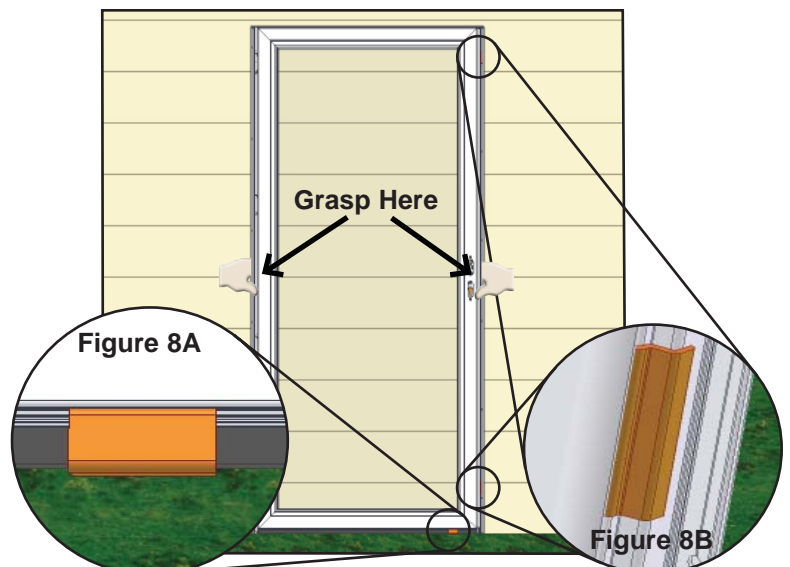

Figure 8

3. HANG HINGED STORM DOOR

Tools needed:



LEFT HANDED - EXTERIOR VIEW

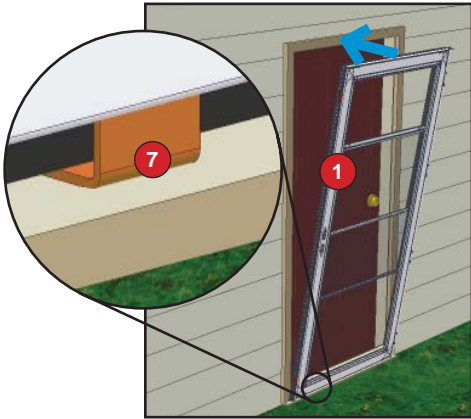

Figure 9

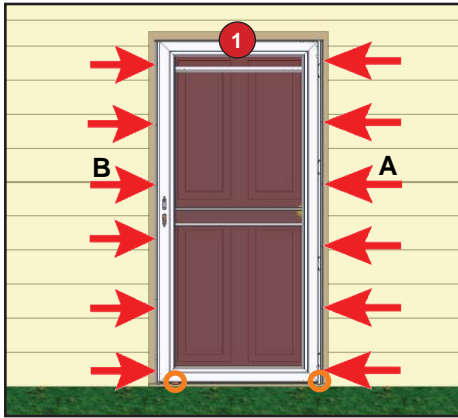

Figure 10

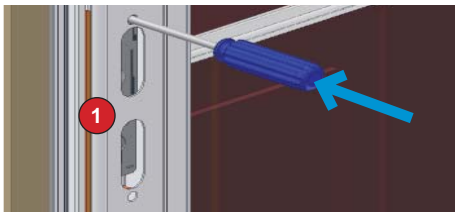

Figure 11

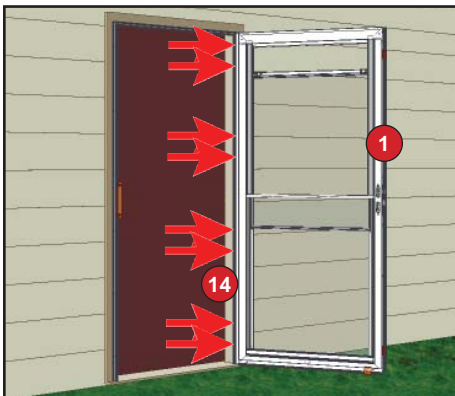

Figure 12

In this step, you will place the door in the opening and fasten it to the mounting surface.

1. Set bottom of door into opening, centering it in the opening. Ensure orange bottom spacer is sitting on door sill. (Figure 9)
2. Tip the top of the door into the opening while ensuring the bottom of the door frame rests on the orange spacer. (Figure 9).

TIP: Place foot against door bottom while tipping the top of the door frame assembly into the opening.

3. The door frame assembly is properly seated in the opening when both the latch rail and hinge rail are flush against the mounting surface and the hinge z-bar and bottom spacer (highlighted in yellow) are resting on the door sill. (Figure 10)

NOTE: The gap between the top of the door and the raincap is intentionally uneven at this step. The gap will become even in later steps.

4. While holding door in position, use the 1/8" drill bit (included in the closer kit) to drill a hole in the mounting surface through pre-drilled holes marked "A" and "B" in figure 10.
 5. Fasten the door to the mounting surface using two #8 x 1 screws (Figure 10).
 6. Pre-drill holes in the mounting surface through the remaining ten pre-drilled holes in the side rails.
 7. Fasten the door to the mounting surface using ten #8 x 1 screws.
 8. Remove two handle hole fasteners by inserting a phillips screwdriver into the handle hole and firmly pressing them out. (Figure 11) Properly discard orange handle fasteners.
 9. Grasp the edge of the door and firmly pull the door open
- NOTE: DO NOT OPEN DOOR BY PULLING ON THE HANDLE HOLES, INJURY COULD RESULT.
10. Using the 1/8" drill bit, drill holes in the door jamb through the holes in the hinge rail.
 11. Fasten the hinge rail to the door jamb using eight #8 x 1 screws (Figure 12). Do not overtighten the screws.

RIGHT HANDED - EXTERIOR VIEW

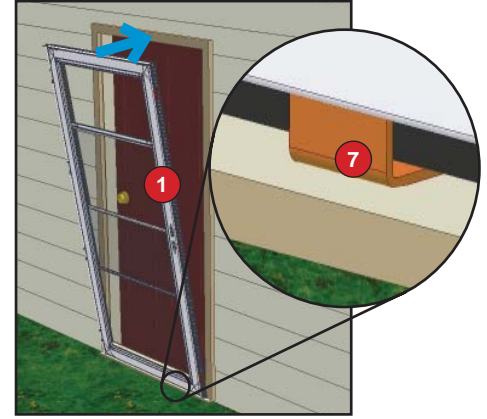

Figure 9

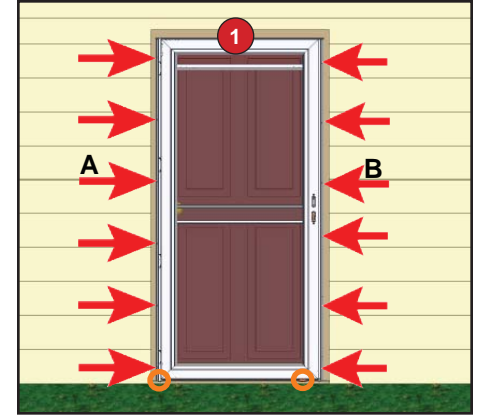

Figure 10

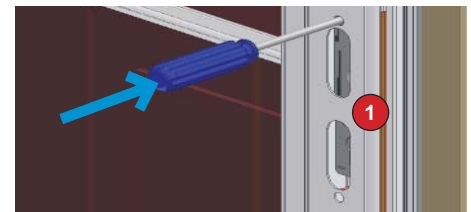

Figure 11

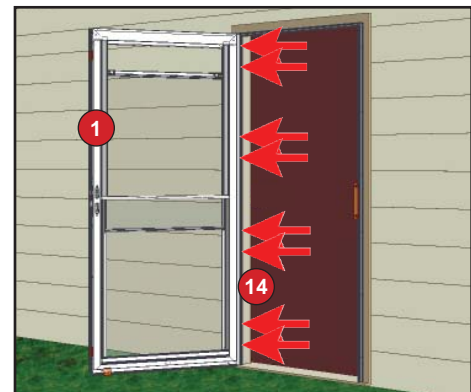

Figure 12

4. REMOVE INSTALLATION CLIPS AND PROTECTIVE FILM

Tools needed:



LEFT HANDED - EXTERIOR VIEWS

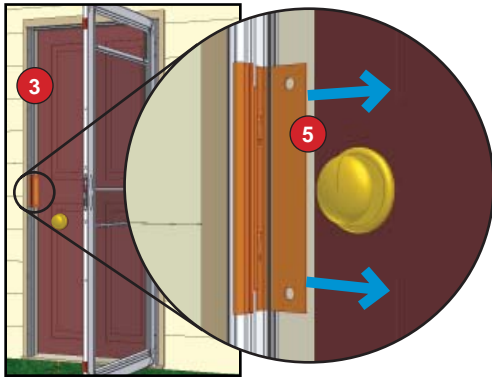

Figure 13

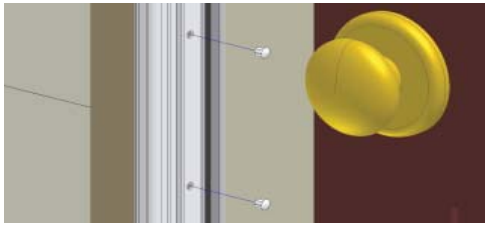

Figure 14

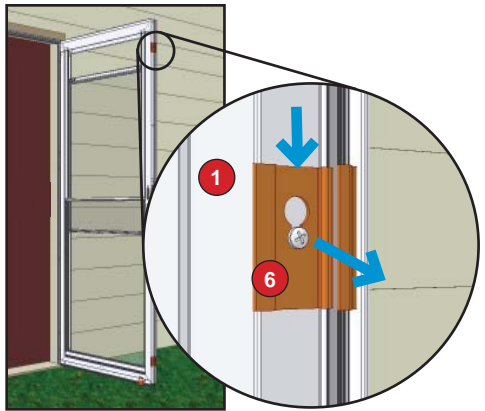

Figure 15

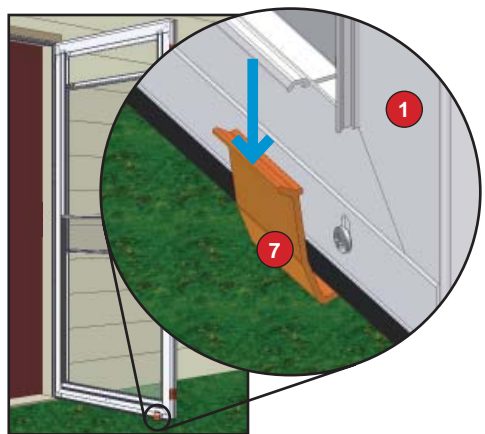

Figure 16

In this step, you will remove and discard all orange installation clips.

1. Grasp handle clip and pull away from latch rail to remove. (Figure 13)

2. Fill holes in latch rail with color matched plugs. (Figure 14)

TIP: Use a screw driver to loosen and tighten screws in Steps 3 and 4; a drill may strip the screw holes. If screws do strip, replace with #10 x 1/2" screws included in the closer kit

3. Remove spacer clips by loosening, but not removing screws, then remove clip. (Figure 15)
4. Re-tighten screws.

5. Remove bottom spacer by pressing down on raised lip. (Figure 16)
6. Properly discard all orange clips.
7. Starting at the mitered corners, remove the clear protective tape from both the interior and exterior of the door frame, if applicable.

RIGHT HANDED - EXTERIOR VIEWS

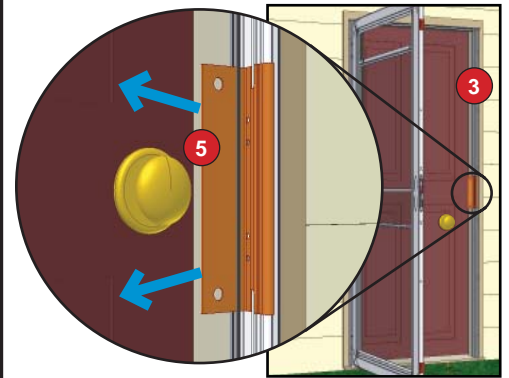

Figure 13

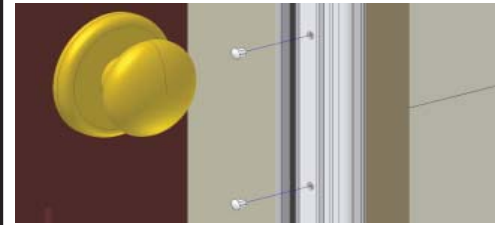

Figure 14

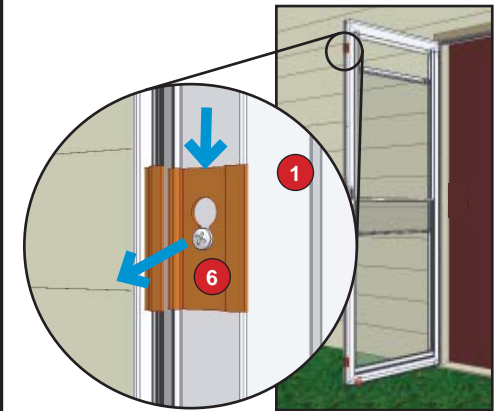

Figure 15

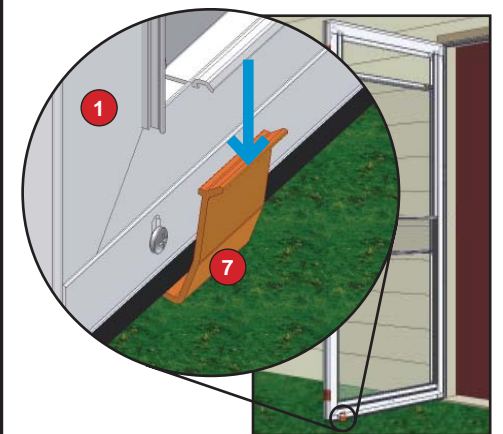

Figure 16

5. INSTALL HANDLE SET

Tools needed:



2- #8 x 1 1/2"



1- #10 x 1 1/2"



1- #10 x 5/8"

LEFT HANDED - EXTERIOR VIEWS

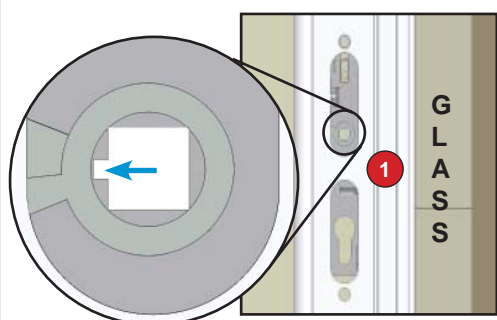

Figure 17

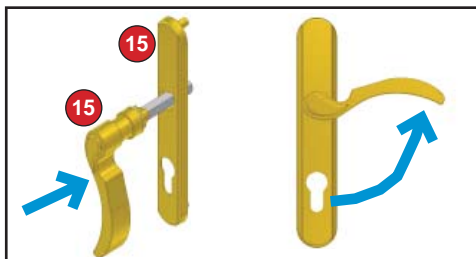

Figure 18

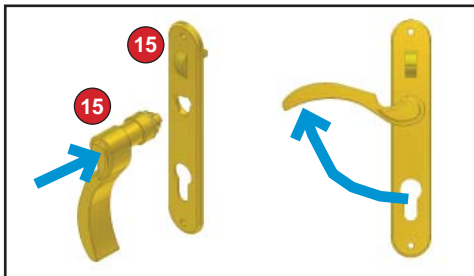

Figure 19

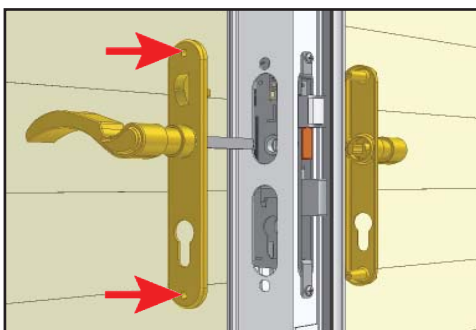

Figure 20

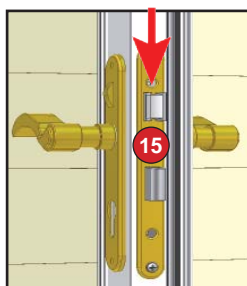

Figure 21

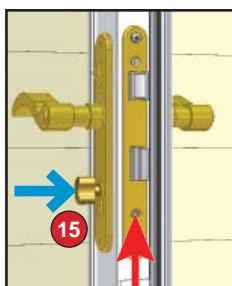

Figure 22

In this step, you will install the handle set.

1. Look into handle holes on door to make sure lock case is oriented properly. The notch in the square spindle hole should be facing away from the glass panel. (Figure 17)

TIP: If the notch is not facing away from the glass panel, use the handle and spindle to rotate the spindle hole into the correct orientation

NOTE: Trim plates should not be installed on the door while completing steps 2 & 3.

2. Insert handle into outside trim plate (with Andersen logo) with lever pointing down and rotate the handle to secure it. (Figure 18)

3. Repeat for other handle and inside trim plate (with slider). (Figure 19)

4. With handle levers held horizontal, install both handle assemblies onto the door. The spindle will pass through the square hole in the lock case and into the other handle. Attach trim plates together using two #8 x 1 1/2" screws. (Figure 20)

5. Install lock case trim plate onto lock case and fasten with one #10 x 5/8" screw. Do not overtighten. (Figure 21)

6. Insert dead bolt key cylinder into lock case and fasten with one #10 x 1 1/2" screw. Do not overtighten. (Figure 22)

NOTE: This door features an integrated latch receiver in the latch rail, eliminating the need for a traditional, separate strike plate.

You can match your Andersen storm door lock to Schlage or Kwikset entry door locks. See handle set instructions contained within handle set box for details.

"Kwikset" is a registered trademark of Newfry LLC. "Schlage" is a registered trademark of Schlage Lock Company.

RIGHT HANDED - EXTERIOR VIEWS

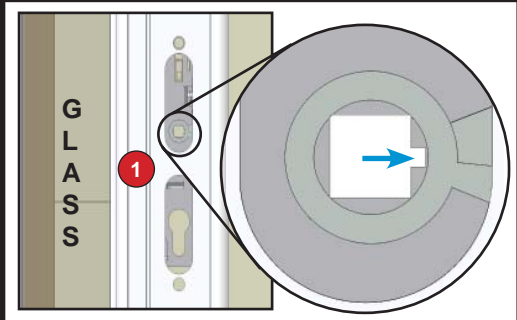

Figure 17

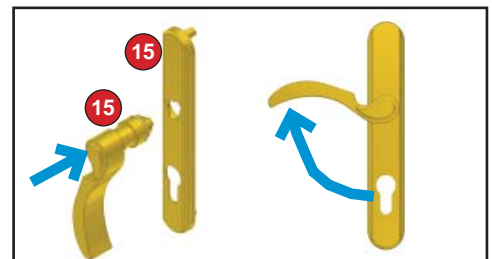

Figure 18

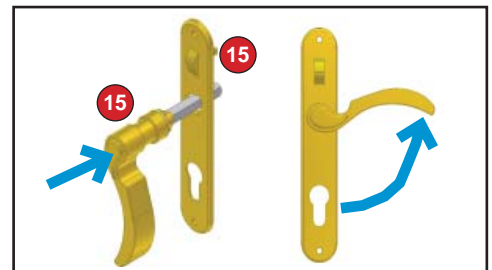

Figure 19

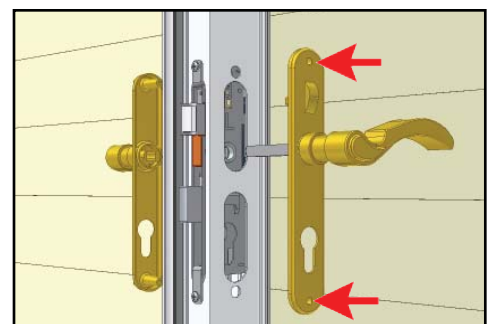

Figure 20

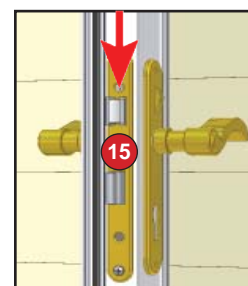

Figure 21

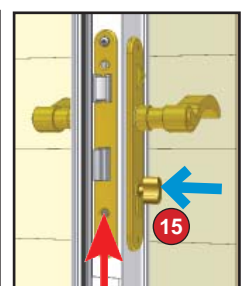

Figure 22

6. INSTALL RAIN CAP MOUNTING FLANGE, SCREW COVERS, AND WINDOW RETAINERS

Tools needed:



LEFT HANDED - EXTERIOR VIEWS

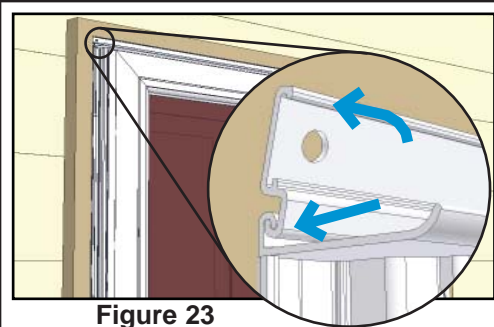

Figure 23



Figure 24

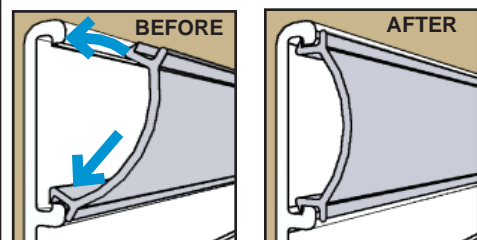
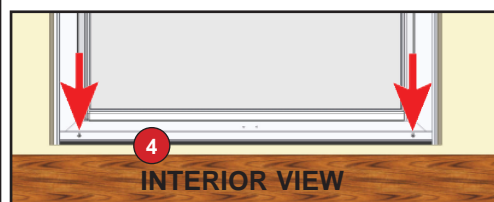

Figure 25

Figure 26



INTERIOR VIEW

Figure 27

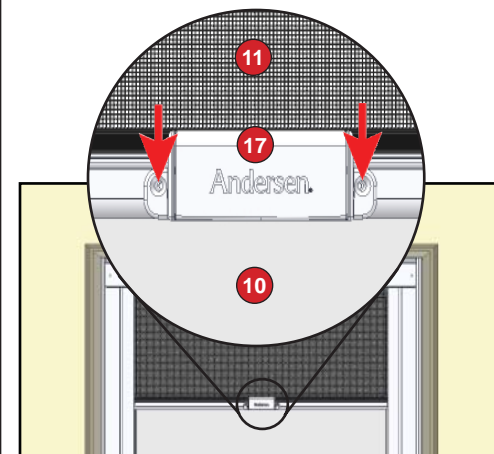

Figure 28

In this step, you will install one of the two rain cap mounting flanges provided.

1. Choose the rain cap mounting flange that best covers the gap present above the rain cap.
2. Hook rain cap mounting flange to rain cap. (Figure 23)
3. While hooked, push up on rain cap mounting flange and use the 1/8" drill bit to a drill hole in the mounting surface through the holes in the flange. (Figure 24)
4. While pushing up on the rain cap mounting flange, fasten flange to the mounting surface with two #8 x 1" screws. (Figure 24)

NOTE: For additional seal against rain, caulk above rain cap mounting flange.

In this step, you will install the screw covers over the mounting screws in the rails and rain cap

5. Starting with the rain cap screw cover, insert a groove in the screw cover into the bottom track of the rain cap. (Figure 25)
6. Snap the groove in the top of the screw cover into the top track of the rain cap. (Figure 26)
7. Move across screw cover, pressing every few inches to snap into track
8. Repeat Steps 5 and 6 to install the remaining side screw covers.

In this step, you will adjust the sweep.

9. Loosen but do not remove the two screws attaching the sweep to the door, lower the sweep until the fins contact the door sill and then re-tighten the screws. (Figure 27)

In this step, attach the window latch.

10. Lower the venting window so the pre-drilled holes below the screen are at a comfortable working height.
11. Align holes in window latch, insert screen pull, and vent window, and attach with two screws (Figure 28).

RIGHT HANDED - EXTERIOR VIEWS

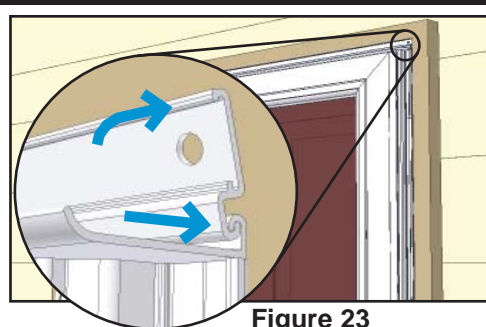

Figure 23



Figure 24

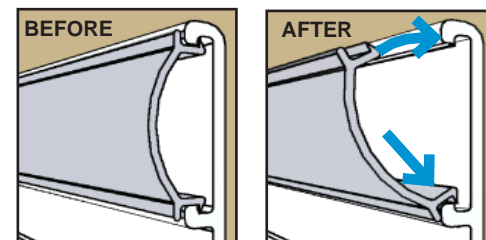
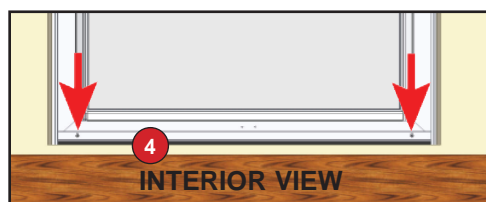

Figure 25

Figure 26



INTERIOR VIEW

Figure 27

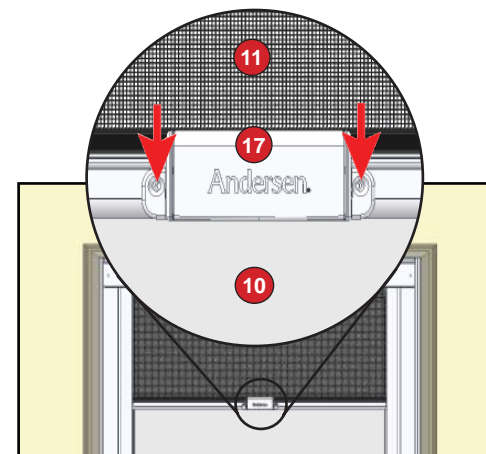
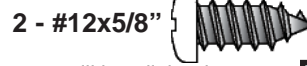

Figure 28

8. INSTALL CLOSERS

Tools needed:



LEFT HANDED - INTERIOR VIEWS

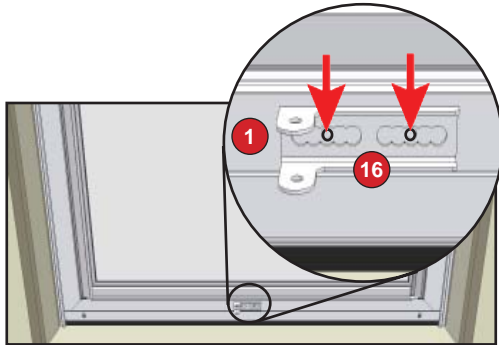

Figure 29

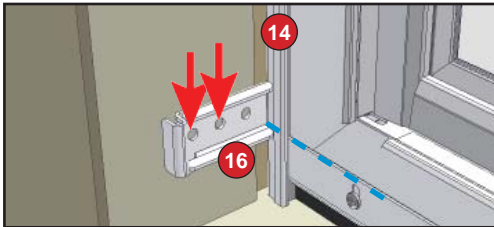

Figure 30

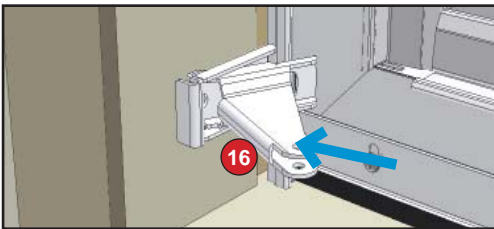

Figure 31

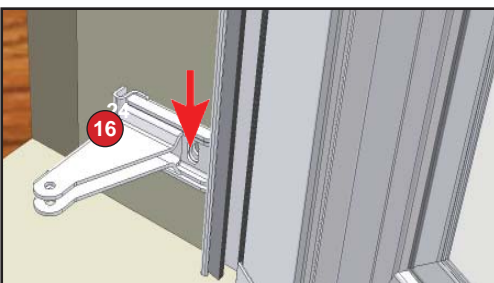

Figure 32

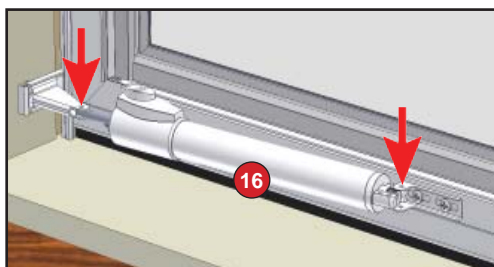

Figure 33

In this step, you will install the door closers.

1. Attach closer door bracket to the door through the two pre-drilled holes using two #12 x 5/8" screws. (Figure 29)

2. Locate closer jamb bracket base on jamb by touching the front of the jamb bracket base to the back of the hinge rail, and align the bottom of the jamb bracket base with the top of the sweep. (Figure 30)

TIP: Jamb bracket base may not always touch hinge rail. If parts do not touch, align the front of the jamb bracket base with the back of the hinge rail.

3. Using the 1/8" drill bit, drill holes in the door jamb through each of the three pre-drilled holes in the jamb bracket base.
4. Attach the jamb bracket base to the door jamb with two #10 x 2" screws into the two holes closest to the interior of the house. (Figure 30)
5. Attach the closer jamb bracket arm to the closer jamb bracket base by inserting the tabs on the jamb bracket arm into the holes in the jamb bracket base. (Figure 31) Secure with one #10 x 2" screw. (Figure 32)

6. Pin bump closer in place using the short pin in the jamb bracket and the long pin in the door bracket (Figure 33)

RIGHT HANDED - INTERIOR VIEWS

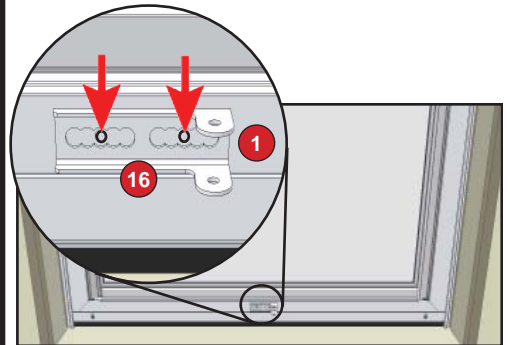

Figure 29

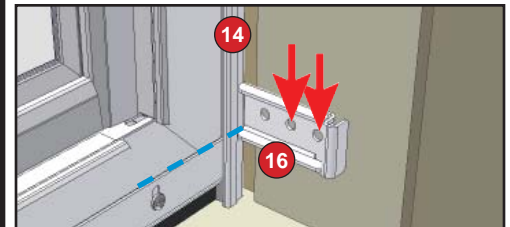

Figure 30

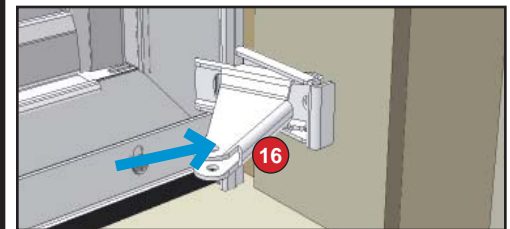

Figure 31

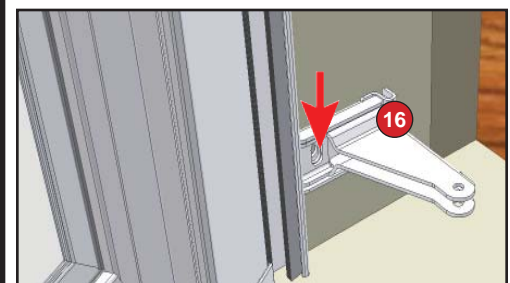

Figure 32

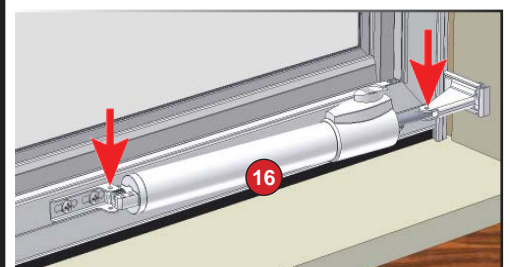

Figure 33

ADJUSTMENTS

Tools needed:



LEFT HANDED - INTERIOR VIEWS

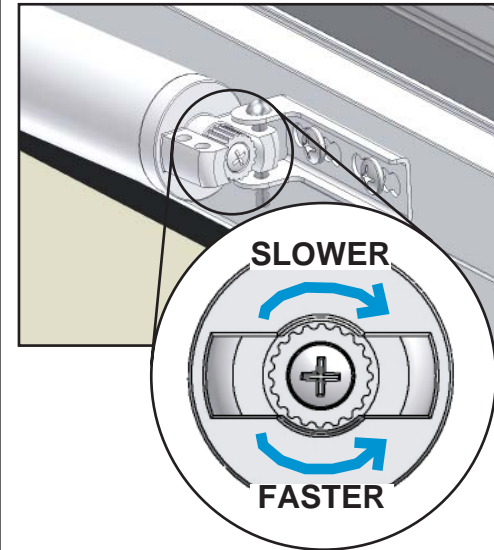

Figure 34

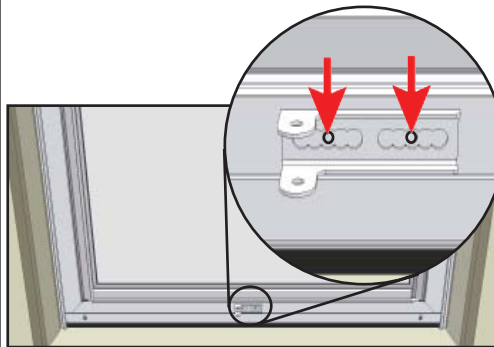

Figure 35

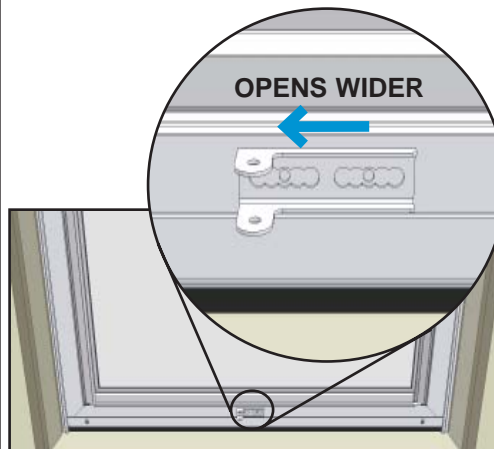

Figure 36

In this step, you will adjust the door closer speed.

1. Locate the adjustment screw at the end of the closer that attaches to the door frame (Figure 34).
2. Open the door and then let it close to note the speed at which the door closes.
3. Using a Phillips head screwdriver to adjust the closer to the desired speed:
For a faster closing speed, turn the adjustment screw to the left (counterclockwise).
For a slower closing speed, turn the adjustment screw to the right (clockwise).
4. Test the speed at which the door closes after each adjustment. Adjust the screw more, if needed, to achieve the desired door closing speed.

RIGHT HANDED - INTERIOR VIEWS

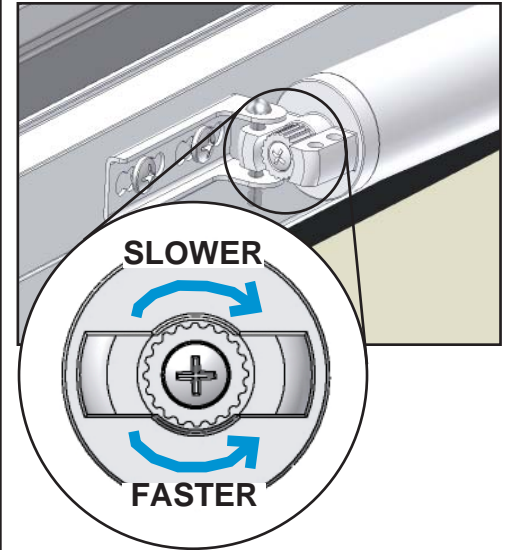

Figure 34

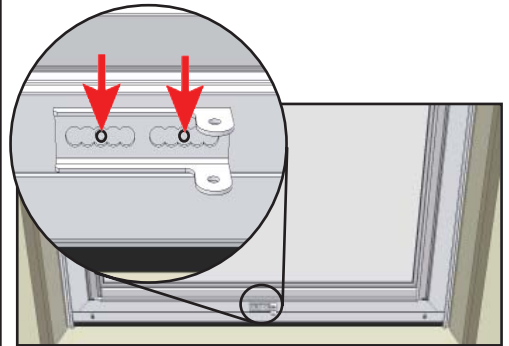

Figure 35

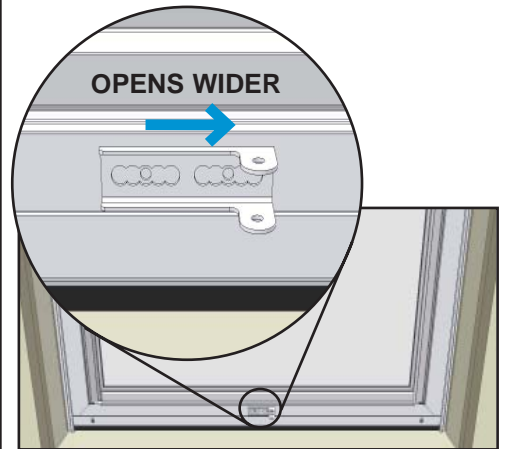

Figure 36

You can adjust how far your storm door opens. Complete the following steps to adjust the opening width of your storm door.

1. Open door as wide as possible. If this width is acceptable, you are done, if larger opening is desired, continue to step 2.
2. Remove closer pins
3. Remove screws holding closer door bracket to door. (Figure 35)
4. Move the door bracket closer to the hinge rail to allow the door to open wider. (Figure 36)
5. Re-attach closer door bracket to door through pre-drilled holes in door with #12 x 5/8" screws.

LEFT HANDED - INTERIOR VIEWS

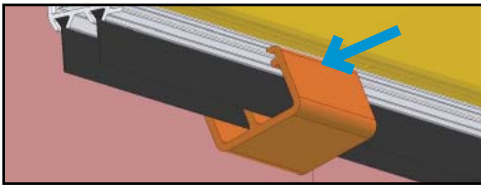

Figure 37

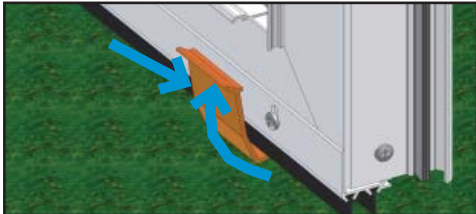

Figure 38

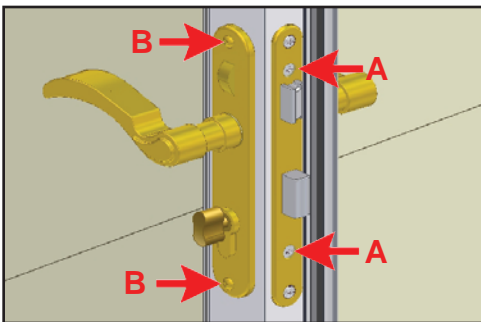

Figure 39

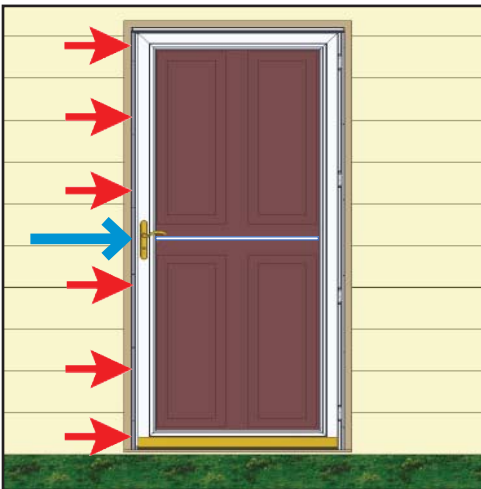

Figure 40

If your bottom spacer falls off or is out of position prior to fastening the door to the mounting surface follow the steps below to re-attach it to the door.

1. Hook the clip on to the sweep (Figure 37)
2. Rotate the clip until it snaps over the back of the sweep (Figure 38)
3. Slide the clip until it is touching the sweep screw on the handle side of the door. (Figure 38)

If your handle binds or does not spring back, follow the steps below.

1. Slightly loosen key cylinder and trim plate screws. (A in Figure 39)
2. Test handleset, if the handle moves freely you are done, if it still binds proceed to step 3.
3. Slightly loosen escutcheon plate screws (B in Figure 39).

If your door is not latching into your latch rail follow the steps below.

1. Remove screw cover (if installed) from the latch rail.
2. Remove six #8 x 1" screws from latch rail. (Figure 40)
3. Push latch rail towards door frame until latch falls into the opening in the latch rail. (Figure 40)

NOTE: If you can see holes in the mounting surface through the holes in your latch rail, you will need to drill new holes in your latch rail. Use the 1/8" drill bit to drill holes 1" above or below existing holes.

4. Fasten the latch rail to the mounting surface using six #8 x 1" screws (Figure 40)
5. Re-install screw cover (see step 6)

For additional help with these, or any other installation steps, please call our Solution Center at 1-800-933-3626

RIGHT HANDED - INTERIOR VIEWS

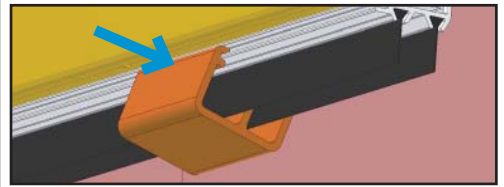

Figure 37

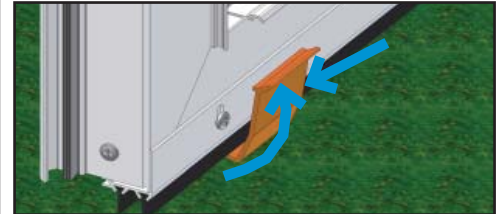

Figure 38

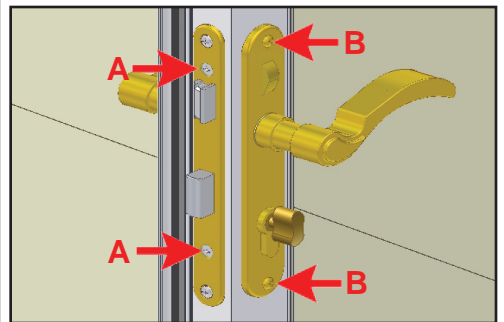

Figure 39

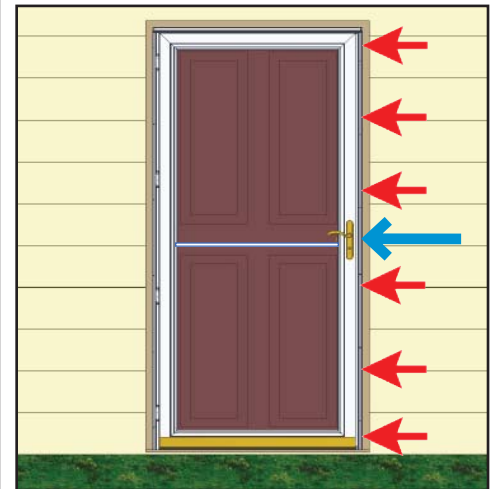

Figure 40

REGULAR MAINTENANCE

WINDOW GLASS – The glass may be cleaned with any household glass cleaner. Keep glass cleaners away from painted parts and brass/nickel components.

PLASTIC PARTS – Plastic door components may be cleaned by using a mild soap and water mixture and by gently rubbing the affected area. Do not use harsh abrasives or any product that contains chlorine.

ALUMINUM PARTS – Aluminum parts on the door may be cleaned by using a mild soap and water mixture and by gently rubbing the affected area. Mineral spirits may be used and will not harm the paint. This will remove many items such as glue residue. Do not use harsh abrasives or any product that contains chlorine.

HANDLE COMPONENTS – Brass handles and components (except coming on windows) may be cleaned in the following manner: Brass handles and components are coated with a clear urethane finish which protects the brass from tarnishing. In order to clean the brass, this coating will have to be removed. Upon doing this, a larger area of brass will be exposed and subject to weathering. Use a high quality brass polish according to the specific directions on that product. A clear urethane may be reapplied to the clean surface to protect the finish. Painted handles and components may be cleaned by using a mild soap and water mixture and by gently rubbing the affected area. **Do not use harsh abrasives or any product that contains chlorine.**

ANODIZED FINISHED SWEEPS – The anodized finished sweep may be cleaned with a mild solution of soap and water. Do not use harsh abrasives or any product that contains chlorine.

BRASS/NICKEL GLASS CLEANING – Brass and Nickel components may be cleaned with good quality cleaner; such as Brasso®.

LIMITED WARRANTIES

PRODUCT LIMITED WARRANTY

DOOR FRAME: EMCO Enterprises, Inc. (EMCO) warrants the door frame, hinges, and painted finish on Andersen® aluminum storm door products to be free from defects in manufacturing, materials, paint adhesion, or workmanship, under normal use, for as long as the original consumer purchaser owns the home in which the door was initially installed.

COMPONENTS: EMCO warrants the non-glass and non-insect screen fabric components of Andersen® storm doors (including brass and nickel hardware finish and the mechanical functions of balancers, locksets, closers, windows and insect screens) to be free from defects in manufacturing, materials and workmanship for a period of five (5) years from the date of original retail purchase or for as long as the original consumer purchaser owns the home in which the door was initially installed, whichever is shorter. Insulated glass is also warranted for a period of five (5) years not to develop, under normal conditions, any material obstruction of vision resulting from manufacturing defects or as a result of premature failure of the glass or hermetic seal.

In the event a door frame, hinges, insulated glass or a component fails as a result of a defect in manufacturing, materials or workmanship within the limited warranty period specified above, and upon written proof of purchase, EMCO, at its option, will provide a replacement door frame, hinge, insulated glass unit and/or components without charge – installation is not included. Such replacement or repair is warranted for the remainder of the original limited warranty period. Please locate the door serial number and written proof of purchase and contact EMCO Consumer Support at 1-800-933-3626. Warranty claims made one (1) year after purchase are subject to a flat processing fee.

“OOPS-PROOF” INSTALLATION LIMITED WARRANTY

EMCO Enterprises, Inc. (EMCO) warrants that any part lost or mis-cut during the original installation of your Andersen storm door will be repaired or replaced at no additional charge within ninety (90) days of the date of original purchase. This limited warranty will not apply if the part has been misused, abused or altered. Cutting parts not specified by the installation guide or mis-drilled parts are not included in this warranty.

In the event a part is lost or mis-cut within the limited warranty period, EMCO, at its option, will provide the appropriate replacement part – installation is not included. Please locate the door serial number and written proof of purchase and contact EMCO Consumer Support at 1-800-933-3626.

GENERAL LIMITED WARRANTY INFORMATION

The limited warranties set forth in this document are the only express warranties (whether written or oral) applicable to Andersen® storm doors, and no one is authorized to modify or expand these limited warranties. All warranty claims must be made during the applicable warranty periods.

ALL IMPLIED WARRANTIES INCLUDING MERCHANTABILITY AND FITNESS FOR A PARTICULAR PURPOSE ARE LIMITED TO THE APPLICABLE STATUTE OF LIMITATION, BUT IN NO CASE WILL EXTEND BEYOND THE TERM OF THE LIMITED WARRANTIES SET FORTH ABOVE. EMCO EXCLUDES AND WILL NOT PAY FOR INCIDENTAL OR CONSEQUENTIAL DAMAGES, WHETHER ARISING OUT OF CONTRACT, TORT OR OTHERWISE, AND ITS LIABILITY WILL IN ALL INSTANCES BE LIMITED TO THE REPAIR OR REPLACEMENT OF THE DEFECTIVE PRODUCT.

Some states do not allow the exclusion of incidental and consequential damages, or limitation of the duration of an implied warranty, so the above limitations or exclusions may not apply to you.

This limited warranty gives you specific legal rights, and you may also have other rights that may vary from state to state and in Canada.

What is NOT covered by this limited warranty: damage caused by 1) improper installation, maintenance, or use; 2) chemicals or airborne pollutants, such as salt or acid rain; 3) acts of God, including wind damage; 4) products not manufactured by EMCO

EMCO Enterprises, Inc. is a wholly owned subsidiary of Andersen Corporation. EMCO manufactures Andersen® and EMCO® storm doors. EMCO supports the limited warranties covering Andersen® Storm and Screen Doors. “Andersen”, “EMCO” and all other marks where denoted are trademarks of Andersen Corporation. ©2011 Andersen Corporation. All rights reserved.

Reprinted and effective as of May, 2011.